



Recorder



Flow



Pressure



Temp



Analyzer



Level

Datasheet

pH electrodes/ORP electrodes

Datasheet**pH electrodes/ORP electrodes**

Tool pH electrode is a high-quality sensor for the analysis and measurement of liquid components during industrial automation. These electrodes are known for their use of top-quality materials and components. They are designed as combined electrodes (the measuring electrode and the reference electrode are combined in one shaft). The temperature probe can also be integrated as an option.

Applications

- Wastewater
- Wet Wells
- Oil tanks
- Sumps
- Reservoirs
- Industrial wastewater
- Electroplating plants
- Paper industry
- Drinking water

**Features**

- Adopt international advanced solid dielectric and large area PTFE liquid junction, easy maintenance.
- Long distance reference diffusion path, extends electrode life greatly in harsh environments.
- Electrode is made of high quality low-noise cable, make signal output length greater than 40 meters or more, without interference.
- High accuracy, fast response, good repeat-ability.
- With silver ions Ag / Ag-Cl reference electrode.
- Side or vertically installation to the reaction tank or pipe.
- Electrode can be used interchangeably with similar electrodes.

Product name

Electrode model	Designation	pH and ORP range	Temperature range
Tool-PHELE-5013A	PTFE pH electrode	0-14pH	0-60°C
Tool-PHELE-5015	High Temperature Glass	0-14pH	0-130°C
Tool-PHELE-5018	Glass pH electrode	0-14pH	0-100°C
Tool-PHELE-5022	Glass pH electrode	0-14pH	0-130°C
Tool-PHELE-6001	Plastic pH electrode	2-12pH	0-80°C
Tool-PHELE-6002	Glass pH electrode	0-14pH	0-100°C
Tool-PHELE-7001	Desulfurization electrode	0-14pH	5-80°C
Tool-PHELE-7002	Plastic pH electrode	0-14pH	5-80°C
Tool-PHELE-7003	Plastic pH electrode	2-12pH	5-80°C
Tool-PHELE-6050	Plastic ORP electrode	-2000mV-2000mV	0-60°C



Tool-PHELE-5022

▪ **Technical parameters**

Zero potential point: 7 ± 0.5 pH
 Conversion coefficient: $> 96\%$
 Installation size: PG13.5
 Pressure: 1 ~ 6 Bar at 25 °C
 Temperature: 0 ~ 130°C for general cables
 Thread Connection: K8S

▪ **Application**

Industrial wastewater engineering including process measurements, electroplating plants, paper and drinks industry, wastewater containing oil.
 Suitable for suspensions, varnishes, media containing solid particles and media containing fluorides (hydrofluoric acid) up to 1000 mg/l HF.



Tool-PHELE-5013A

▪ **Technical parameters**

Temperature compensation: Pt100/Pt1000/NTC10K
 Zero potential point: 7 ± 0.25
 Conversion coefficient: $\geq 95\%$
 Membrane resistance: $< 500\Omega$
 Practical response time: < 1 min
 Salt bridge: Cyclic tetrafluoro salt bridge
 Reference: Ag/AgCl
 Pressure resistance: 0.3MPa
 Thread Connection: 3/4NPT
 Material: PTFE

▪ **Application**

Low-impedance glass sensitive film, wear-resistant, strong acid and alkali resistant, with protection ring in the front to protect glass bulb and better precision and linearity.



Tool-PHELE-5018

▪ **Technical parameters**

Temperature compensation: Pt100/Pt1000/NTC10K
Pressure resistance: 0.25MPa
Connector: VP, S8M, K2, etc.
Zero potential point: 7 ± 0.5 pH
Conversion coefficient: > 98%
Membrane resistance: general: <250M Ω
Practical response time: < 1 min
Salt bridge: Porous ceramic core/ porous Teflon
Thread Connection: PG13.5

▪ **Application**

In various chemical processes including microbial technology, pharmaceuticals, food and beverages, sugar manufacturing, chlor-alkali, mining and smelting, papermaking, paper pulp, textiles, petrochemical industry and semiconductor electronic industry as well as fields such as sewage treatment



Tool-PHELE-5015

▪ **Technical parameters**

Temperature compensation: Pt100/Pt1000/NTC10K
Connector: VP, S8M, K2, etc.
Zero potential point: 7 ± 0.5 pH
Conversion coefficient: > 98%
Membrane resistance: general: <250M Ω
Practical response time: < 1 min
Salt bridge: Ceramic salt bridge
Pressure resistance: 0.25MPa
Thread Connection: PG13.5
Reference:Ag/AgCl
Material:Glass

▪ **Application**

In various chemical processes including microbial technology, pharmaceuticals, food and beverages, sugar manufacturing, chlor-alkali, mining and smelting, paper pulp, textiles, petrochemical industry and semiconductor electronic industry as well as fields such as wastewater treatment.



Tool-PHELE-6050

▪ **Technical parameters**

Zero potential point: 7 ± 0.5 pH
Conversion coefficient: $> 96\%$
Pressure resistance: ≤ 0.6 MPa
Thread Connection: 3/4NPT

▪ **Application**

In various industrial processes including sewage and waste gas treatment and fields.



Tool-PHELE-6001

▪ **Technical parameters**

Temperature compensation: Pt100/Pt1000/NTC10K
Pressure resistance: 0.4MPa
Reference: Ag/AgCl
Thread Connection: 3/4NPT
Salt bridge: Cyclic tetrafluoro salt bridge
Material:ABS

▪ **Application**

In various chemical processes including water treatment, waste gas treatment, aquaculture and dosing equipment supporting.



Tool-PHELE-6002

▪ **Technical parameters**

Measurement range:(0~14) pH
Temperature range:(0~100)°C
Pressure resistance:0.6MPa
Zero potential point: $E_0=7\text{pH}$
Electrode size: $\phi 12 \times 120$, 225 or other sizes
Thread: PG13.5, international standard
Electrode outer tube material: glass
Wire: 5 meters (standard), optional
Temperature compensation resistance: Pt100, Pt1000, 2.252K, 10K, 22K, etc

▪ **Application**

In various chemical processes including microbial technology, pharmaceuticals, food and beverages, sugar manufacturing, chlor-alkali, mining and smelting, papermaking, paper pulp, textiles, petrochemical industry and semiconductor electronic industry as well as fields such as sewage treatment



Tool-PHELE-7001

▪ **Technical parameters**

Temperature compensation: Pt100/Pt1000/NTC10K
Pressure resistance: 0.4MPa
Reference: Ag/AgCl
Thread Connection: 3/4NPT
Salt bridge: Ceramic salt bridge
Material: PPS

▪ **Application**

In various chemical processes including high suspended solids solution, lime pool and mining.



Tool-PHELE-7002

▪ **Technical parameters**

Temperature compensation: Pt100/Pt1000/NTC10K
Pressure resistance: 0.4MPa
Reference: Ag/AgCl
Thread Connection: 3/4NPT
Salt bridge: Cyclic tetrafluoro salt bridge
Material:PPS

▪ **Application**

In various industrial processes including sewage and waste gas treatment and fields.



Tool-PHELE-7003

▪ **Technical parameters**

Measuring range: (2~12)pH
Temperature range: (5~80)°C
Pressure resistance: 0.6MPa
Temperature compensation type: NTC10K, PT100, PT1000
Reference type: Ag/AgCl
Salt bridge: Cyclic tetrafluorosalt bridge
Mounting thread: 3/4NPT
Shell material: PPS

▪ **Application**

The industrial pH electrode adopts a ring-type polytetrafluoroethylene liquid junction, a solid electrolyte and a special glass sensitive membrane, which enhances the electrode reaction speed and anti-pollution ability

Installation of electrode

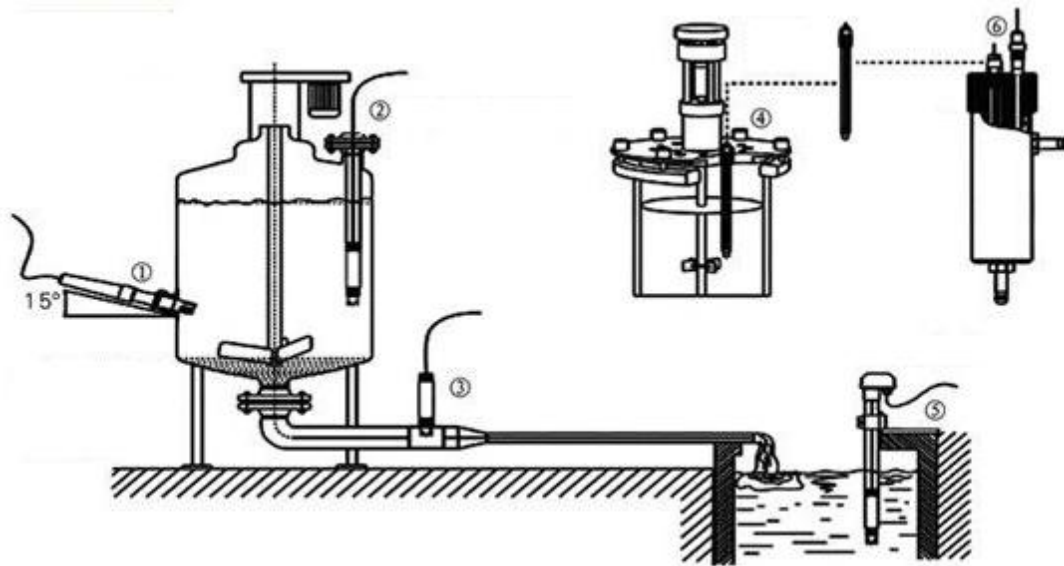

Schematic diagram of common installation method

- ① Side wall installation
- ② Flange mounted at the top
- ③ Pipe installation
- ④ Top installation
- ⑤ Submersible installation
- ⑥ Flow-through installation

The interface must be in 5 oblique angle, or it will affect the normal test and use of the electrode. We won't be responsible for any results due to this.

pH Calibration

A pH calibration is the procedure of adjusting the pH meter by measuring solutions of known pH values.

The characteristic of a pH electrode will change with time due to electrode coating and aging. And even a pH electrode would be stable over time, pH electrodes cannot be produced with identical characteristics.

In practice the response of a real pH sensor does not exactly follow the Nernst equation. This difference between the theoretical and actual behavior of a pH electrode must be compensated for. A calibration is required to match the pH meter to the current characteristics of the used pH sensor.

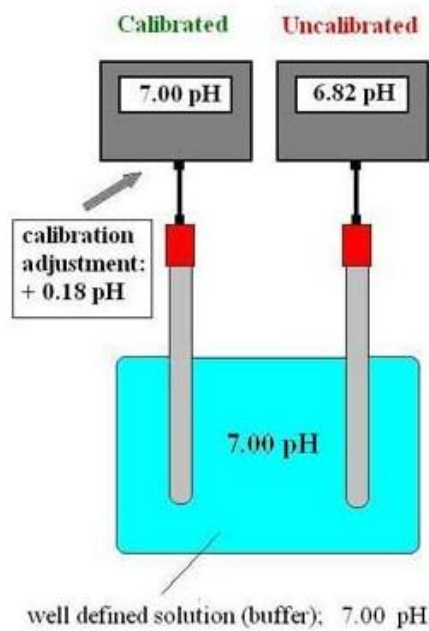

To achieve the best possible accuracy, the calibration should cover the range of the desired measurement values. If the readings go beyond the calibrated range, the pH meter assumes linearity and simply extrapolates the value to be displayed. The true value may be slightly different.

More advanced pH meters will let the user calibrate at three, four or five and even higher numbers of pH values. A multi-point calibration mean, in comparison to a two-point calibration, that you can calibrate your pH tester on both sides of the zero point (pH 7.00). This will expand your pH measurement range without the need of recalibrating.

Example) Three-point calibration at pH 4.00 , 7.0 and 9.21.

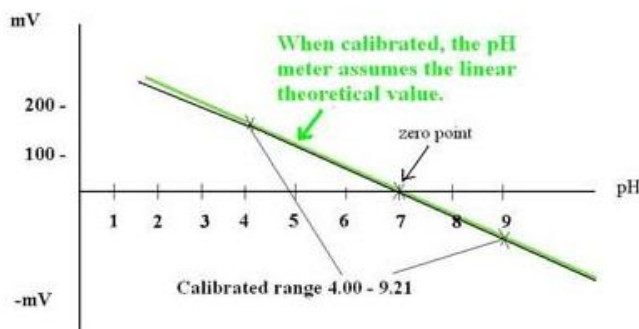

Electrode slope: The slope of the glass electrode is 59.16 mV at 25 °C theoretically, i.e. potential change of 59.16 mV for each pH change in the solution. But in fact, neither glass electrode can reach the theoretical value 100%; in general, the electrode slope is more than 98% of the theoretical value (percentage slope). In addition, the mV difference corresponding to each unit pH value varies under different temperatures. The conversion of temperature to electric potential difference is as follows:

$$\Delta E = 59.16 \cdot \left[\frac{273 + T}{298} \right] \cdot \Delta \text{pH}$$

Corresponding relationship between pH and millivolt at 25°C

Potentiometer(mV)	pH	Potentiometer(mV)	pH
414.12	0.00	-414.12	14.00
354.96	1.00	-354.96	13.00
295.80	2.00	-295.80	12.00
236.64	3.00	-236.64	11.00
177.48	4.00	-177.48	10.00
118.32	5.00	-118.32	9.00
59.16	6.00	-59.16	8.00
0.00	7.00	0.00	7.00

Related Product



PTFE pH sheath



Stainless steel pH sheath



Flow cup



Electronic controlled box